

Drawing #: 60226W-212-G
60226 Dual LCD Monitor Arm Wall Mounted Assembly

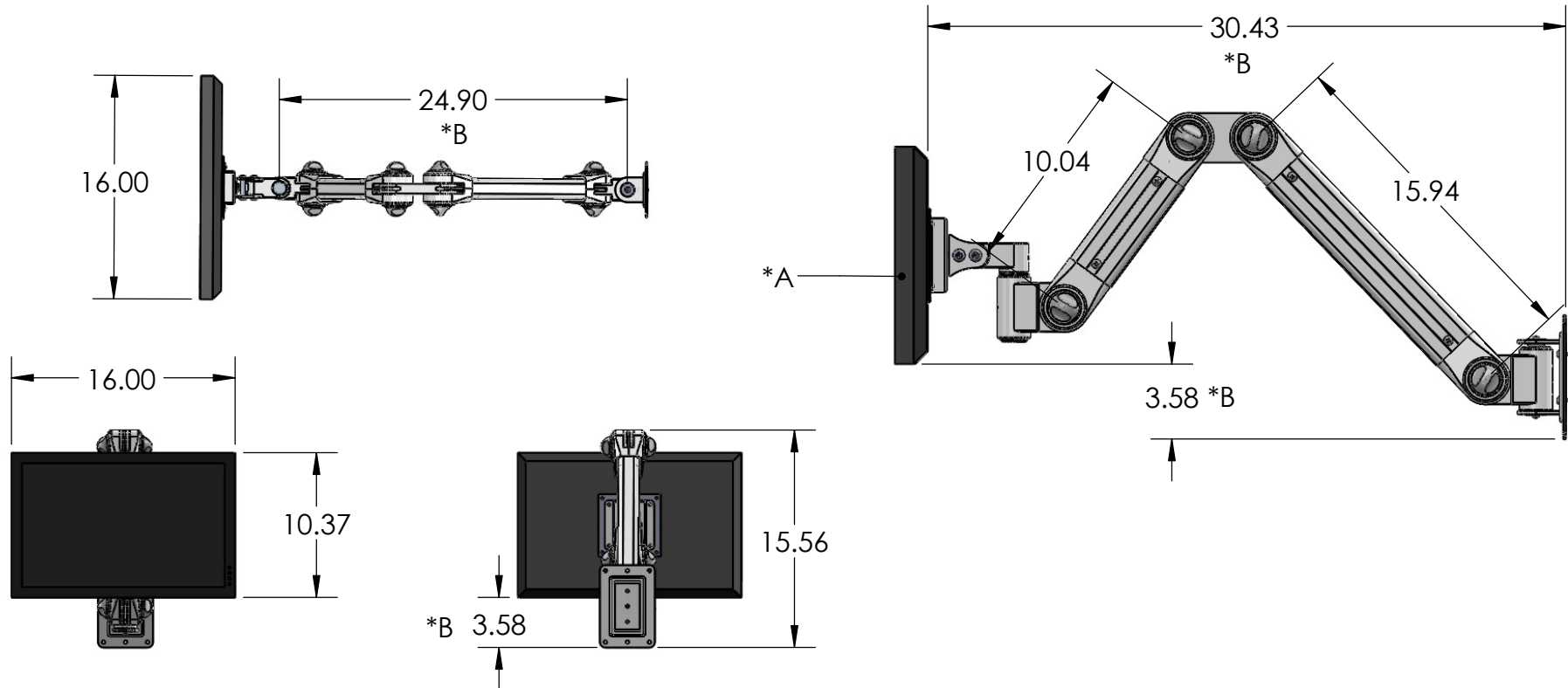

*A: Monitor dimensions are for drawing purposes only. Customer monitor may differ. Monitor NOT included in assembly
*B: Monitor arm assembly shown in a standard operational position. Some dimensions may vary based on positioning.

PROPRIETARY AND CONFIDENTIAL
THE INFORMATION CONTAINED IN THIS DRAWING IS THE SOLE PROPERTY OF CUSTOM PRODUCTS AND SERVICES. ANY REPRODUCTION IN PART OR AS A WHOLE WITHOUT THE WRITTEN PERMISSION OF CUSTOM PRODUCTS AND SERVICES IS PROHIBITED.

		UNLESS OTHERWISE SPECIFIED:		NAME	DATE	
		DIMENSIONS ARE IN INCHES TOLERANCES: FRACTIONAL ± ANGULAR: MACH ± BEND ± TWO PLACE DECIMAL ± THREE PLACE DECIMAL ±		DRAWN	NJN	1/6/14
				CHECKED		TITLE: Wall Mount Dual LCD Monitor Arm
				ENG APPR.		
				MFG APPR.		
		INTERPRET GEOMETRIC TOLERANCING PER:		Q.A.		
		MATERIAL		COMMENTS:		
		FINISH				
NEXT ASSY	USED ON					SIZE A
APPLICATION		DO NOT SCALE DRAWING				DWG. NO. 60226W-212-G
						REV
						SCALE: 1:12
						WEIGHT:
						SHEET 1 OF 1